

# GLASS & SOLID COMBINATION HALF-DOOR UPRIGHT REACH-IN REFRIGERATOR

## TOP MOUNT CONDENSING UNIT

Project Name: \_\_\_\_\_

Project Location: \_\_\_\_\_

Model #: \_\_\_\_\_ Quantity: \_\_\_\_\_

Available Warehouse: \_\_\_\_\_

**ES Series**

**Model: EGS4**



### Refrigeration System

- Top mounted, self-contained and fully detachable condensing unit uses environmentally friendly R404A\* refrigerant with zero (0) Ozone Depletion Potential (ODP) and EPA compliant R290 refrigerant with zero (0) Ozone Depletion Potential (ODP) and three (3) Global Warming Potential (GWP). R290 condensing units are replaceable and require no on-site brazing. \*Ask about alternative refrigerant.
- PSC evaporator fan motors for R404A models. Electronically commutated (ECM) fan motors for R290 models.
- Airflow guard ensures optimal circulation of cold air. R290 models include full-length air duct system.
- Time-initiated and temperature-terminated auto defrost heater for R404A and R290 freezers. Air defrost for R290 refrigerators.
- Large capacity, corrosion-resistant condenser and evaporator coils.
- Self-maintaining, energy-efficient condensate drain pan requires no external drains or electric heaters.
- High performance condenser fan motors ensure efficient compressor ventilation. R290 models use auto-reverse condenser fan motors which also support condenser coil cleaning. Refer to owner's manual for full maintenance instructions.
- Pressure relief devices allow smooth access to cabinet interior when reopening doors.
- Pre-wired and ready to plug, 115V/60Hz/1Ph, NEMA 5-15P.

### Cabinet Construction

- Heavy duty stainless steel interior / exterior with rounded corners for a hazard-free workspace.
- Open spaced interior with no walls between compartments.
- Galvanized steel top, bottom and rear.
- 2.5" thick high density polyurethane insulation.
- Four 5" swivel casters with locks on front set.

### Lighting

- Shielded LED bar lighting with on/off switch provides bright, high color illumination at lower heat output.

### Doors

- Low emissivity double glass panes and matte finish aluminum door frames for glass doors.
- Heavy duty stainless steel interior / exterior with 2.5" thick high density polyurethane insulation for solid doors.
- Frame heaters prevent exterior moisture build up.
- Self-closing with adjustable torsion system for a positive seal.
- Snap-in magnetic door gaskets make cleaning and replacement an easy process.
- Heavy duty, die-cast door handles for glass doors. High strength, recessed door handles for solid doors.
- Pre-installed door locks keep your items safe from theft.

### Shelving

- Four epoxy coated, steel wire shelves per section.
- Height adjustable stainless steel clips.

### Temperature Control

- Multi-function digital controller with easy to read LED display.
- Factory preset temperature, 35°F. Temp-set range from 33°F to 54°F.
- Audible overheat protection alarm for compressor and condenser coil.

### Options

- Additional shelving.
- 3" swivel casters with locks.
- 3.5" – 6" height-adjustable and interchangeable legs.



Please visit our website for updated Energy Efficiency information

Ref/ Frz/Dual	Doors	Capacity Cu. Ft.	Shelves	Refrigerant	HP	Power V-Hz-Ph	Amps	Crated Weight	Exterior Dimensions		
									L	D	H*
REF	4(H)	48	8	R-290	1/3	115-60-1	2.7	449 lbs (204kg)	49.625" (1260mm)	31.625" (803mm)	74.25" (1886mm)

(†)Based on evaporating temperature of 23°F (-5°C) & condensing temperature of 131°F (55°C). (►) Product capacity is calculated based on standard industry figures. (✳) Reference plan view for clarification on caster/unit height. If dimensions and capacity are critical, please contact Everest Refrigeration. Blizzard R290 replacement is at the sole discretion of Everest Refrigeration. Specifications subject to change without notice.

# GLASS & SOLID COMBINATION HALF-DOOR UPRIGHT REACH-IN REFRIGERATOR

## TOP MOUNT CONDENSING UNIT

**ES Series**

**Model: EGS4**

### DIMENSIONAL DATA

External Dimensions	L	49.625" (1260mm)
	D	31.625" (803mm)
	H*	74.25" (1886mm)
Crated Weight		449 lbs. (204kg)
Doors/Drawers/Lids		4(H)
Max Weight Support (LBS)		-

### STORAGE DATA

Net Capacity Cu. Ft. ▶	48
Shelves	8
Barrels	-
20 oz. Bottles	-
12 oz. Bottles	-
12 oz. Cans	-
8" Mugs	-
# of Pans (Top)	-
# of Pans (Drawer)	-
Dividers	-
Trays	-

### ELECTRICAL DATA

Voltage	115-60-1
Full Load Amperage	2.7A
Feed Wires with Ground	3
Cord Length	9ft
NEMA Plug Type	 NEMA 5-15P

### REFRIGERATION DATA

Compressor Mounting	Top
Refrigerant	R-290
Compressor HP	1/3
BTU/HR †	2311

### KEY

D	Door	R	Refrigerator
L	Lid	REF	Refrigerator
H	Half Door	F	Freezer
FD	Full Door	FRZ	Freezer
SD	Solid Door	DUAL	REF/FRZ Combo
GD	Glass Door	DR	Drawer

	Elevation	Right	Plan	3D	Back

### PLAN VIEW

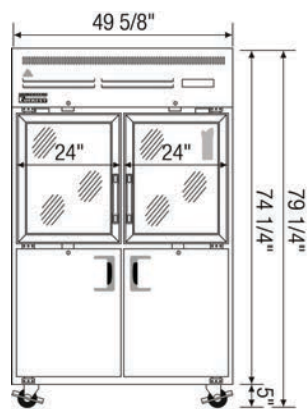

▲ EGS4

**FRONT**

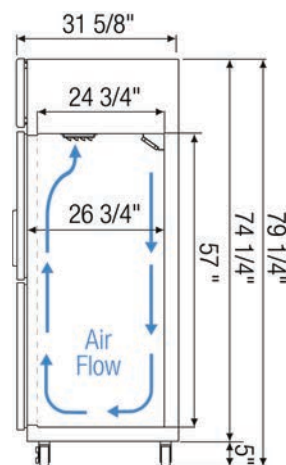

**SIDE**

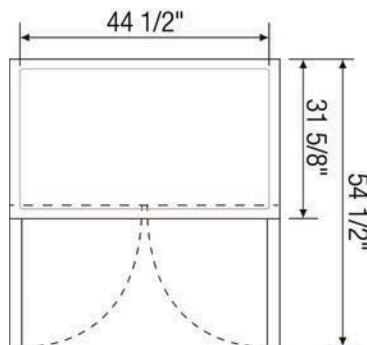

**TOP**

### ACCESSORIES & OPTIONS

Part Number	Description
<b>Additional Shelving</b>	Contact Everest Refrigeration for more information.
<b>AJL03-00</b>	Interchangeable Leg for Caster (Optional)
<b>CASA3-01</b>	3" Overall Height Caster Assembly - (2) Front (2) Rear

(†)Based on evaporating temperature of 23°F (-5°C) & condensing temperature of 131°F (55°C). (▶) Product capacity is calculated based on standard industry figures. (✳) Reference plan view for clarification on caster/unit height. If dimensions and capacity are critical, please contact Everest Refrigeration. Blizzard R290 replacement is at the sole discretion of Everest Refrigeration. Specifications subject to change without notice.